

Track Cleaning

In normal operation, model railway layouts may accumulate dirt on the running surfaces of the rails, some of which will be transferred to the locomotive's pick-up wheels. This will have two adverse effects:

- (a) loss of locomotive traction and, if allowed to build up,
- (b) reduction or total loss of power to the locomotive motor.

It is therefore essential that the track **and** wheels, are kept absolutely clean. This can usually be done by wiping the surfaces with a clean, non-fluffy cloth. More stubborn deposits can be removed by using a small piece of "Scotch" washing-up pad which can be obtained from the "Household" section of most supermarkets.

A more convenient and realistic method of keeping rails clean is to use R296 Track Cleaning Coach which should be **pushed** around the track by the locomotive.

Locomotive Bodywork

Hornby Railways locomotive and tender bodies are spray painted overall. The rest of the decoration is applied by a printing process and not transfers. Please do not use any solvent-type agents to clean bodies. If necessary, use a dry, soft, non-fluffy cloth to keep the body clean.

Couplings

Coupling units are clipped into position on bogie and tender rear. To replace a coupling unit, pull coupling horizontally out of its location and push in replacement firmly until clip snaps into place.

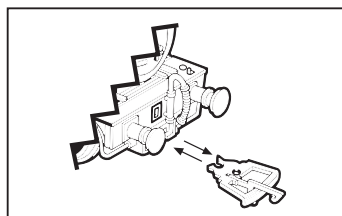

Television Suppression

Hornby locomotives incorporate radio and television interference suppressors. Should interference occur despite these precautions, it may be due to the close proximity of the layout to receivers, or aerials and their "downlines". In this case, please move the layout further away from aerials and receivers.

It is most important that track, and pick-up wheels are kept absolutely clean.

"County" Class Locomotive & Tender

The cab footplate (A) must be angled upward before connecting locomotive and tender together. This will eliminate the risk of the footplate becoming jammed in the tender, which would cause the unit to derail.

After locomotive and tender are connected, the footplate can be pushed back to its horizontal position to overlap the front edge of the tender.

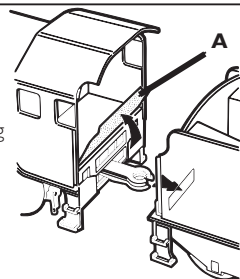

Safety Notes

- This locomotive is not suitable for children under 3 years of age because of small parts which can present a choking hazard. Some components have functional sharp edges – handle with care.
- This locomotive is intended for indoor use only.
- The transformer is not a toy. It is a "Transformer for Toys". Before use, check that the transformer is the correct voltage for your mains electricity supply. This locomotive is only to be used with the recommended transformer. The transformer should be examined regularly for damage to the casing, plug pins and cables.

In the event of such damage, the set should not be used until the transformer is replaced with a new Hornby recommended unit. Never attempt to open the transformer yourself.

- This locomotive must not be connected to more than the recommended number of power supplies. The output terminals of the transformer must not be connected directly, or indirectly, to the output of any other AC circuit derived from a transformer or mains power supply.
- Before cleaning any part, disconnect the transformer from the mains electricity supply. **Do not use liquid for cleaning.**
- Please retain these details for future reference.

Spare Parts and Service

Spare parts packs can be obtained from Hornby Service Dealers who are also able to offer a repair service.

HORNBY®

PLEASE READ RIGHT THROUGH THESE NOTES CAREFULLY, PARTICULARLY THE SAFETY NOTES ON PAGE 4

TYPE 8 RINGFIELD MOTOR – 4-6-0 CASTLE AND COUNTY LOCOMOTIVES Locomotive Operation and Maintenance Instructions

General

Hornby locomotives are precision built and, if treated with reasonable care, will give many years of good service. Whilst there are many different locomotives, there are common aspects in their use and handling.

Warning – On certain locomotive models, electrical connectors and handrail fittings etc. have functional sharp edges and points. **Please handle with care.**

Important – The electric motors of Hornby locomotives are designed to be operated from a variable 12 volts, DC, power supply only. This is obtained from the domestic mains electricity supply by using a Hornby Transformer and a Train Controller.

NEVER CONNECT A LOCOMOTIVE DIRECTLY TO THE MAINS ELECTRICITY SUPPLY.

The 12 volt DC supply is picked up from the track through the wheels on one side of the locomotive and returned by the wheels on the other side. It is therefore essential that the running surface of the rails, and the metal tyres of the pick-up wheels, are kept absolutely clean (see notes on track cleaning on page 4).

The current drawn by locomotives varies between .2 amp and .6 amp depending on type of locomotive, load and track gradient. There will be a current surge on starting locomotives.

The Ringfield motor and main electrical pick up from the track is incorporated in your locomotive with additional pick-ups fitted in the tender. The locomotive and tender are designed to be run correctly coupled together for maximum efficiency.

Motor and chassis mechanisms may pick up fluff, carpet fibres and pet hairs which can get entangled in the gears and around axles. It is important to check periodically and remove any such debris with tweezers.

Connecting Locomotive and Tender

Place locomotive and tender on the track. Make sure that both plastic and metal drawbars are lined up together and insert the ends into the corresponding slot at the front of the tender. Holding both locomotive and tender, firmly push them together until the drawbar clip snaps into position.

"County" locomotive owners, please refer to notes on page 4.

Running Hints

If a locomotive does not respond normally to the power controller, or runs badly, check the following points:

- All electrical connections are made correctly and wall power socket is switched "ON".
- Power connecting clip is correctly inserted into a suitable section of track.
- All track sections are correctly fitted together and all fishplates (rail-joiners) are fitted tightly onto adjoining metal rails.

In any correspondence
please quote Ref. No:



- All locomotive wheels are positioned correctly on track.
- Direction control switch on train controller is set to operate in one direction or the other, and not in central "OFF" position.

Lubrication

Although locomotives are lubricated before despatch from the factory, the lubricant can dry out during storage. Lubrication should be carried out at approximately 6-monthly intervals, or every 100 hours of running time. **DO NOT OIL THE MOTOR.**

A light machine oil such as "3 in 1" can be used. PLEASE USE CAUTION, as mineral oils of this type can cause deterioration to the polystyrene plastic from which Hornby locomotive bodies are manufactured. Immediately wipe off, with a cotton rag, any oil which gets onto a locomotive body. Refer to the lubrication notes given on page 3. An oil dropper can be made by straightening a paper clip and sticking one end into a cork (Fig.1). Fill a small container with oil so that the smallest possible drop can be "picked up" by the dropper and carefully applied to the correct place. Immediately wipe off any excess oil.

IMPORTANT – Apply oil only to moving parts. Keep oil away from wheel rims and track.

Fig. 1

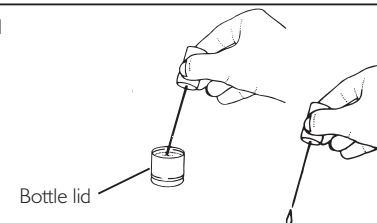

Routine Maintenance

After approximately 100 hours of running time, the carbon brushes in the Ringfield motor may have become worn out, resulting in the locomotive's speed being reduced or it not responding well to the train controller. If this happens, the carbon brushes will need to be replaced. It is strongly recommended that you have this work carried out by an Official Hornby Service Dealer.

Details are given on carbon brush replacement procedures on pages 2 and 3. **This work should only be attempted by an adult who has gained some experience in such work and who is used to working with small tools. Please read right through the instructions before attempting any of the following processes.**

HORNBY®

To remove locomotive body (Fig. 2)

Turn the locomotive over onto a clean soft surface and carefully remove the brake rod detail, referring to the separate leaflet provided with the brake rod detail.

Remove bogie securing screw (A) and bogie. This provides access to front body screw (B).

Remove front body screw (B), bogie spring and rear body screw (C) which allows the plastic and metal drawbars to be removed through the slot in the cab rear. Take care to keep body and chassis firmly together and carefully turn over locomotive onto its wheels (Fig. 2a).

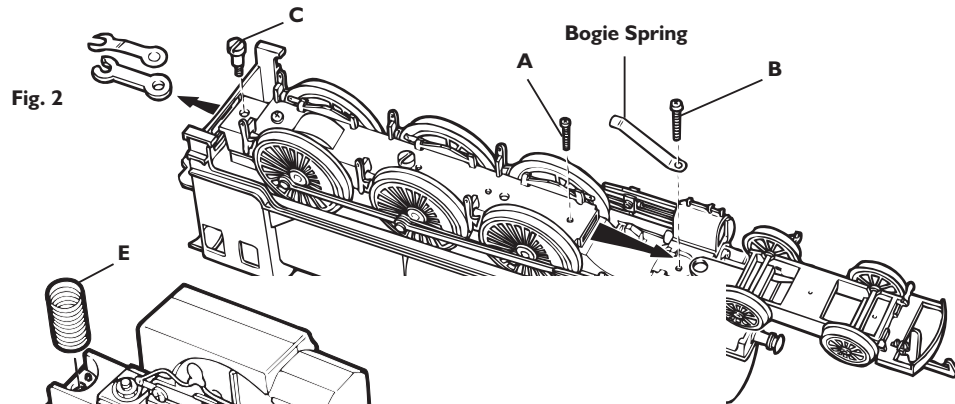
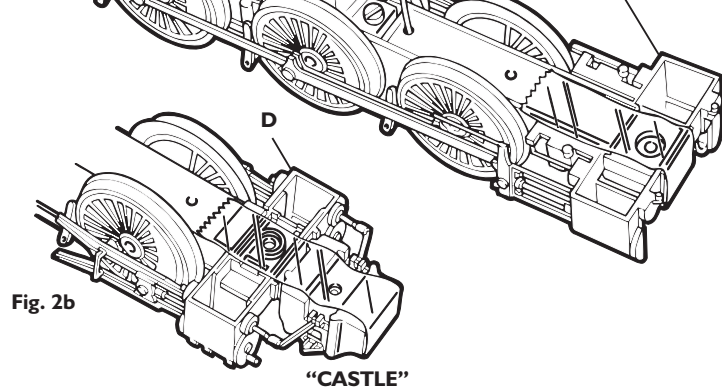

Fig. 2a



Carefully lift body from chassis assembly without disturbing the position of the cylinder block (D). Immediately secure the cylinder block in place with a piece of clear adhesive tape (see Figs. 2a and 2b). This will avoid the necessity to reposition cylinder block and valve gear which can be a complicated process.

Remove contact spring (E) and keep safely until re-assembly.

To replace motor brushes and springs (Fig. 3)

Caution – The brush contact screws help to hold the motor unit together. Therefore, complete one brush renewal before starting to replace the other one.

Lay chassis assembly on its side on a clean sheet of white paper with motor brush contacts uppermost.

Remove brush contact screw (F) and lift clear brush contact (G). Remove brush spring (H) and any remains of the old carbon brush – it may be necessary to turn chassis assembly over and gently tap it to do this.

Fit new brush and spring and refit brush contact, repeating the process for the replacement of the second brush and spring.

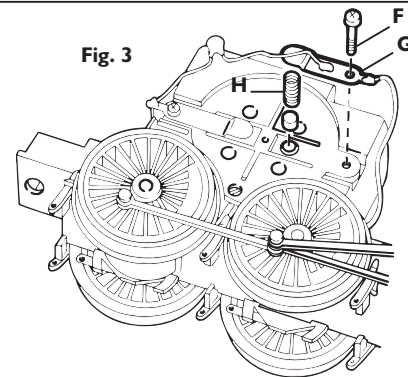
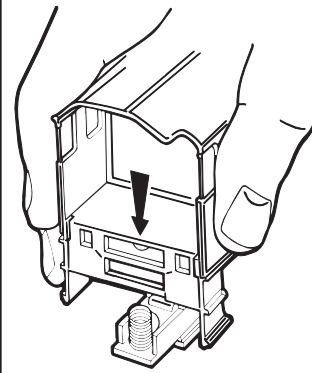

Fig. 3

Fig. 4a



To refit body

Remove the clear adhesive tape holding the cylinder block in place.

Place the contact spring (E) in position on the chassis assembly.

Carefully lower the locomotive body onto the chassis assembly, trapping the drawbar contact spring in position (Fig. 4a).

Firmly holding body and chassis assembly together, turn over locomotive onto its top and refit bogie spring with screw (B) referring to Fig. 2. This will hold body and chassis together while you refit drawbars.

Fig. 4b

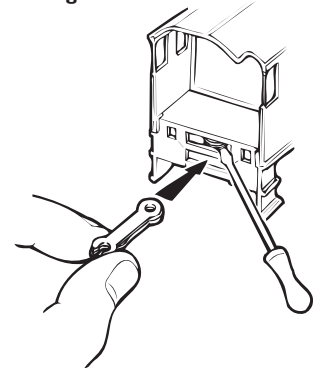

Through the upper slot of the cab rear, use a flat-bladed screwdriver to lift the coils of the drawbar contact spring to allow both drawbars to be slid into position underneath it, through the lower slot. (Remember that the metal drawbar must be underneath when the tender is right way up).

Refit screw (C) making sure it passes through both drawbars and contact spring.

Refit bogie by inserting end of bogie drawbar into position and replacing screw (A) making sure it passes through bogie drawbar hole.

Replace brake rod detail to underside of locomotive referring to separate leaflet.

Fig. 5

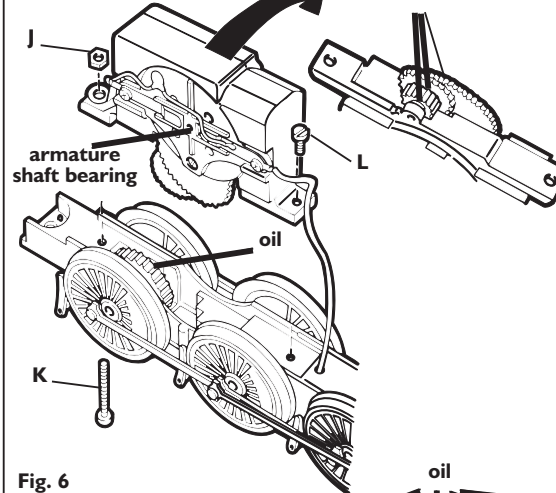

Lubrication

To lubricate the motor gears it will be necessary to remove the locomotive body as detailed in Figs. 2, 2a and 2b. Remove the motor unit, which is held in position by nut (J) and bolt (K) and screw (L). Lift and turn over the motor unit to expose all of the gears. Lubricate with one drop of oil on each gear or use a small amount of any light grease recommended for model railways.

Lubricate armature shaft bearings on both sides of motor with one drop of oil.

Lubricate locomotive axle bearings and connecting rods with just one drop of oil in each of the places indicated (Fig. 6).

Fig. 6

